

Table of Content

1. Function Description.....	1
2. Installation.....	1
3. Input requirements.....	2
3.1. Input voltage.....	2
3.2. Frequency.....	2
3.3. Inrush current.....	2
3.3.1. Cold start.....	2
3.3.2. Warm start.....	2
3.4. AC input current.....	2
3.5. Efficiency.....	2
4. Output	3
4.1. Output regulations.....	3
4.2. Power distribution configuration.....	3
4.3. Cross regulation.....	3
4.4. DC output voltage ripple and noise.....	4
4.5. Remote ON/OFF control.....	4
4.6. Power sequency.....	4
4.7. Power on time(T1).....	5
4.8. Rise time(T2).....	5
4.9. Power Good delay time(T3).....	5
4.10. Power Good rise time(T4).....	5
4.11. Hold up time(T5).....	5
4.12. Power fail signal(T6).....	5
5. Protections.....	5
5.1. Over voltage protection.....	5
5.2. Short circuit protection.....	6
5.3. Protection reset.....	6
5.4. Over shoot.....	6
5.5. Over power protection.....	6
5.6. Over temperature protection.....	6
6. Environment.....	6
6.1 Operation/storage temperature range.....	6
6.2 Smart temp. control feature.....	6
6.3 Humidity (None condensing).....	7
6.4. Altitude.....	7
7. Regulatory compliance.....	7
8. Dielectric voltage withstand(Hi-pot).....	7
9. MTBF.....	7
10. Precaution.....	7
11. Simple maintenance.....	8
12. Power connector drawing.....	8

1. Function Description

This power supply is designed for personal computer. There are six DC outputs: +5V, -5V, +12V, -12V, +3.3V & +5V_{SB}, and it provides power to all computer systems and peripherals with maximum protection.

Here are some of the key features:

- **Passive Power Factor Correction(Optional)**
- **Surge Current Protection**
- **Input Transient Voltage Protection**
- **Over Voltage Protection**
- **Over Power Protection**
- **Short Circuit Protection**
- **Painted Aluminum Enclosure**
- **Fanless no noise design**

This power supply family is designed w/o cooling fan therefore results in complete silence. Heat generated and raised in the power supply unit is conducted via heatsink and finally release to the air.

2. Installation

It is rather simple to install this power supply to your precious computer tower. Follow the steps below to finish the installation.

Step1: Open the computer tower cover; put the power supply into the corresponding location of the tower, and then use right screws to fix the power supply to tower.

Step2: Put the Main Power Connector, ATX12V Connector, AUX connector, Peripheral Connectors and Floppy Connectors to the corresponding male connectors of main-board, peripheral devices (i.e. HDD, CDROM etc.) and floppy drivers respectively. When you connect connectors, please pay attention to the orientation of them because of the different hole sizes. Find the proper orientation and push down firmly making sure that the pins are aligned.

3. Input Requirements

3.1. Input Voltage

The power supply shall be operated at the range below:

Input Range	Volt Selector Set
100~120Vac	115
200~240Vac	230

3.2. Frequency

The input frequency range is from 47Hz to 63Hz.

3.3. Inrush Current

The max. inrush current is 45A for 115Vac and 70A for 230Vac, respectively.

3.3.1. Cold Start

Conditions	Limits
115/230Vac, full load, ambient 25degree C	NO component over stress or damage should occur to the power supply. Input fuse shall not blow.

3.3.2. Warm Start

Conditions	Limits
Turn off at 132/264Vac full load for 1 secretary then turn on at the peak of the input voltage cycle at 25 degree C.	NO component over stress or damage should occur to the power supply. Input fuse shall not blow.

3.4. AC Input Current

Model	AC Input	
	115Vac	230Vac
FL-350ATX(CF-350)	8A	4A
FL-420ATX(CF-400)	10A	5.5A
FL-480ATX(CF-480)		

3.5. Efficiency

The power supply efficiency shall not be less than 75% at the maximum load of section 4.2 and 115/230Vac input voltage. While at half load the value shall reach 77% min.

4. Output

4.1. Output Regulations

Output Voltage	Range	MIN	NOM	MAX	Unit
+5V	5%	+4.75	+5.00	+5.00	Volts
+12V	5%	+11.40	+12.00	+12.60	Volts
-5V	10%	-4.50	-5.00	-5.50	Volts
-12V	10%	-10.80	-12.00	-13.20	Volts
+3.3V	5%	+3.14	+3.30	+3.47	Volts
+5Vsb	5%	+4.75	+5.00	+5.25	Volts

Note: The output voltage should be measured at the terminals of output connector.

4.2. Power Distribution Configuration

Output Rail	FL-350ATX (CF-350)	FL-420ATX (CF-400)	FL-480ATX (CF-480)	Cable Color
	Max. 350W	Max. 400W	Max. 480W	
+3.3V	28A	30A	30A	Orange
+5V	35A	40A	45A	Red
+12V	15A	18A	18A	Yellow
-5V	1A	1A	1A	White
-12V	1A	1A	1A	Blue
+5Vsb	2.5A	2.5A	2.5A	Purple

4.3. Cross Regulation

The DC loads shall remain within the ranges specified in 4.2 Power Distribution Configuration and the DC output voltages also shall remain within the regulation ranges specified in 4.1 Output Regulations when measured at the load end of the output connectors.

4.5. DC Output Voltage Ripple and Noise

DC Output	Ripple Max.	Noise Max.	Unit
+5V	75	75	mV
+12V	150	150	mV
-5V	75	75	mV
-12V	150	150	mV
+3.3V	75	75	mV
+5Vsb	100	100	mV

Note: The measurements should be made by crossing a 10 μ F electrolytic and a 0.1 μ F ceramic disk capacitor at each output measuring bandwidth from DC to 20MHz. If ambient temperature is under 20 or over 30, the AC input should be nominal input.

4.6. Remote ON/OFF Control

The power supply outputs shall be enabled with an active-low TTL signal. When TTL signal is low, the DC outputs are to be enabled. When TTL signal is high or open circuited, the DC outputs are to be disabled. Electronic means or a mechanical switch may activate the TTL signal. After the TTL signal is active high, must wait for 3 seconds before active low again.

4.7. Power Sequency

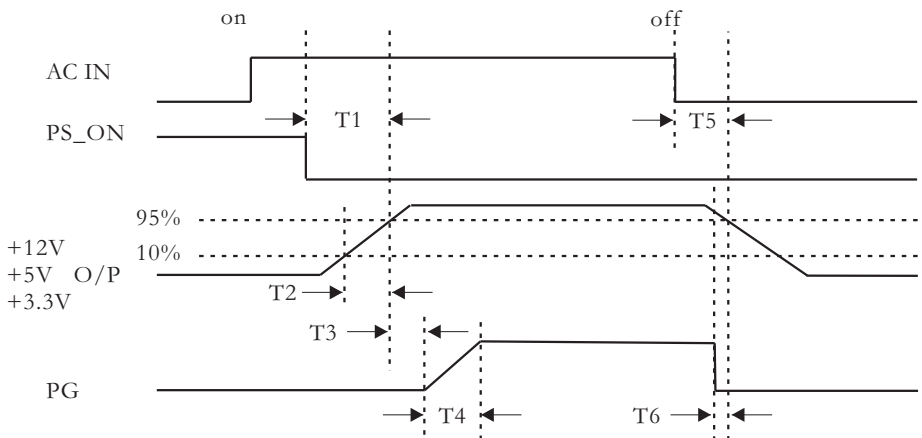

4.8. Power On Time(T1)

MAX	Units
500	ms

4.9. Rise Time(T2)

MIN.	MAX.	Units
0.1	20	ms

4.10. Power Good Delay Time(T3)

MIN.	MAX.	Units
100	500	ms

4.11. Power Good Rise Time(T4)

MAX	Units
10	ms

4.12. Hold Up Time(T5)

MIN.	Units
14	ms

The test environment is 25 degree C & full load @ nominal input.

4.13. Power Fail Signal(T6)

Power good signal shall go to a down level 1ms before +5V output voltage falls below the regulation limits during PS-ON signal

MIN.	Units
1	ms

5. Protections

5.1. Over Voltage Protection

When the DC outputs (+5V, +12V and +3.3V) have over voltage condition, the power supply shall provide latch mode over voltage protection.

DC Output	Trigger Voltage Range
+12V	13.4~15.6V
+5V	5.74~7.0V
+3.3V	3.76~4.3V

5.2. Short Circuit Protection

A short circuit placed on any output shall cause no damage or the power supply shall shutdown. (The contact resistance is 0.05 ohm when outputs short circuit.)

5.3. Protection Reset

When the power supply latches into shutdown condition due to a fault on an output, the protection shall reset after the fault has been removed. Use remote on/off control or recycle the AC power again for a typical of 3 seconds.

5.4. Over Shoot

Any output overshoot at turn on shall be less than 10% of the nominal output value (with resistive load) as described in sec. 4.1.

5.5. Over Power Protection

At 115/230Vac input the power supply will shut down all DC output within 110% to 160% of full load.

5.6. Over Temperature Protection

The power supply shall go to latch when its inner temperature reaches 100 degree C.

6. Environment

6.1. Operation/Storage Temperature Range

Operation: 0 to 50°C

Storage: -20°C to 80°C

(Recommended maximum ambient temp. for long time user is 25°C, while the inner temp. can reach 80°C.)

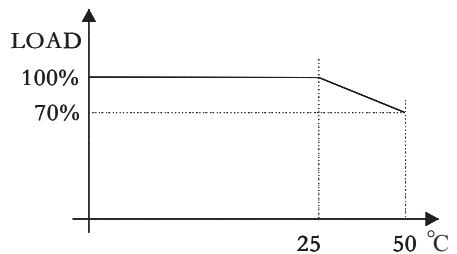

6.2. Smart Temp. Control Feature

There are 2 temperature control LEDs at the rear panel of the power supply. One is green, which indicates power supply running in normal temperature, while the yellow alerts overheated alarm. In normal case only the green led is on, when temperature inside the power supply climbs up and reaches around 60 degree C or above, the green led goes off and the yellow one turns on, warns end user the power supply runs in overheated status; meantime, a chassis fan that is powered by the power supply through a big 4 pin male

Power connector starts to rotate to pull the inner heat outside . When power supply inner temperature decreases below 60 degree C, the fan stops, the yellow led turns off and the green turns on again. In this way to achieve balance between heat and noise, and realize the most possible silence of the system under precondition the system works properly.

6.3. Humidity (none condensing)

Operation: 20% to 85% RH

Storage: 10% to 95% RH

6.4. Altitude

Operation: to 10,000 ft

Storage: to 50,000 ft

7. Regulatory Compliance

UL 60950-1

CAN/CSA-C22.2 NO.60950-1

TUV EN60950-1

FCC part 15 sub part B Class B

8. Dielectric Voltage Withstand (HI-POT)

The power supply shall withstand for 2 seconds without breakdown the application of an 1800Vac supply voltage applied between both input line and chassis (10mA AC Cutoff current). Isolating transformers shall similarity withstand 4242Vdc applied between both primary and secondary windings for a minimum of one minute.

9. MTBF

The power supply shall have a minimum MTBF at continuous operation of 50,000 hours at 100% load, the recommended ambient temperature of 25 degree C and a maximum inner temperature of the power supply at 80 degree C for 230Vac/50Hz and 115Vac/60Hz

10. Precaution

Caution: Unauthorized personnel should not do this to avoid electrical shock!

10.1. Do not open the top cover of the power supply case.

10.2. Please keep the power supply from humidity.

- 11.3. Don't attempt to remove the front panel heat sink at any time, or it may result in a system shutdown.
- 11.4. **HIGH TEMPERATURE!** Don't hand-touch any parts of the enclosure while operation.
- 11.5. Flammable materials must keep far from the front panel heat sink.

11. Simple Maintenance

If power supply cannot work properly, before send for repair, please check the following items:

- 11.1. Does power cord indeed plug into electrical outlet?
- 11.2. Does Input Voltage set in power supply correspond to the main Source in your environment?
- 11.3 Please check the output connectors plugging in proper direction and connecting firmly.
- 11.4 Please check the output connectors plugging in proper direction and connecting firmly.
- 11.5. Having checked above items, if the power supply still does not function, please send it back to your retailer or distributor for repair

12. Power Connector Drawing

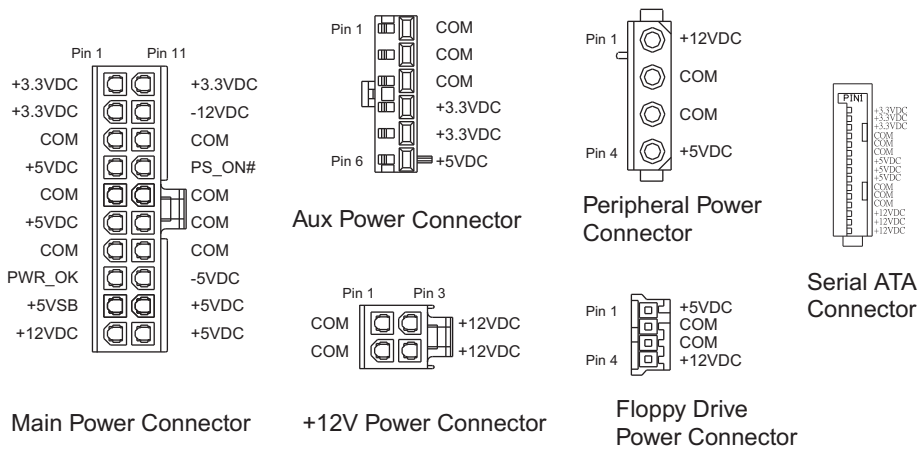

Pin-side view, not to scale