

Table of Content

1	Function Description.....	1
2	How to Setup.....	1
3	Specifications.....	2
4	Precaution.....	3
5	Simple Maintainance.....	4
6	Mechanical Diagram.....	4

1. Function Description

This power supply is designed for personal computer. There are six DC outputs: +5V, +12V, -5V, -12V, +3.3V & +5V_{SB}, and it provides power to all computer systems and peripherals with maximum protection.

Here are some of the key features:

- **14cm fan design, long life, noiseless and fastest cooling time**
- **All kinds of protection circuits (OVP/OPP/SCP)**
- **High efficiency: not less than 75% at full load**
- **Externally selectable 4-band TMS(Thermal Management System: Auto/Low/Mid/High) to meet vast majority end users' demands**
- **S-ATA connector ready**
- **Tube-tide design to tidy the wires**
- **20-24Pin/4-8Pin connectors available to support both 20Pin and 24Pin socket motherboards**
- **Coated chassis**

2. How to Setup

It is rather simple to install this power supply to your precious computer tower. Follow the steps below to finish the setup.

Step1:Open the computer tower cover; put the power supply into the corresponding location of the tower, and then use right screws to fix the power supply to tower.

Step2:Plug firmly the Main Power Connector, ATX12V 4P Connectors, Peripheral Connectors and Floppy Connectors to the corresponding male connectors of main-board, peripheral devices (i.e. HDD, CDROM etc.) And floppy drivers respectively. When you connect the connectors, please pay attention to the orientation of them because of the different hole sizes. Find the proper orientation and push down firmly and be sure that the pins are aligned.

3. Specifications

3.1 Input Requirements

The power supply shall operate as below

115V (100V min.-132V max.), 50Hz

230V (200V min.-264V max.), 60Hz

3.3 DC Output

Power distribution configuration:

Model	+3.3V	+5V	+12V	-5V	-12V	+5V _{SB}
AP-450X (CR-400B)	30A	40A	18A	1A	1A	2.5A
AP-500X (CR-450B)	30A	45A	22A	0.5A	1A	2.5A
AP-550X (CR-500B)	30A	45A	26A	0.5A	1A	2.5A
AP-600X (CP-550B)	30A	55A	35A	0.5A	1A	2.5A

3.4 Protection

The power supply itself is designed with short circuit, over voltage, no load and over power protection functions described as below:

3.4.1 Short Circuit Protection

A short circuit on any DC output will cause the power to latch. The power supply will withstand a continuous short circuit to the output without damage or overseers to the unit. The +5V_{SB} can be shorted indefinitely and will recover automatically when the short is removed.

3.4.2 No Load Operation

No hazardous conditions or damage to the supply will occur with all of the DC output connectors disconnected from the load.

3.4.3 Over Power Protection

When the total load exceed 130%~160% of the maximum output power, the power supply shall be latched into the state of shutdown.

3.5 Physical Environment

Operation Conditions

The power supply shall be capable of continuous operation and meet all electrical specification without need for adjustment when subjected to the following environ-mental conditions:

	Derating Condition	Humidity
Operation	0 ~30°C @ Full Load	10% ~90% RH
	30°C ~40°C @90% Rated Load	
	40°C ~50°C @80@ Rated Load	
Storage	-20°C ~80°C	5% ~90% RH

No degradation of the power supply shall occur during shipping or storage at the specified condition.

3.6 4-Band Thermal Management System

In the front panel of the SPU it equips a temperature control SW. to allow the end-user manually adjusts the supply fan speed so as to minimize the ambient noise level at the precondition that the system works reliably.

Low: Fan speed at 850RPM 10%

Mid: Fan speed at 1000RPM 10%

High: Fan speed at 1200RPM 10%

AUTO: Fan speed is auto controlled by built in smart temp. control circuit.

Caution: The channel Low and Mid are designed for professional users, if you are a new hand, it is strongly suggested to set the switch at AUTO.

3.7 Regulatory Compliance

Our power supply has been certified to comply with multi-national Safety and EMI.

-- UL, CUL, CSA, TUV, FCC

4. Precaution

Caution: Unauthorized personnel should not do this to avoid electrical shock!

4.1 Do not open the top cover of the power supply case.

4.2 Please keep the power supply from humidity.

5. Simple Maintenance

If power supply cannot work properly, before send for repair, check the following items:

5.1 Does power cord indeed plug into power outlet?

5.2 Does input voltage set in power supply correspond to the main source in your environment?

5.3 Please check the output connectors plugging in proper direction and connecting firmly.

5.4 Please turn off the power and turn it on for several times, and the interval must be at least 5 seconds.

5.5 Having checked above items, if the power supply still does not function, please send it back to your retailer or distributor for repair.

6. Mechanical Diagram

6.1. Power Connector Drawing

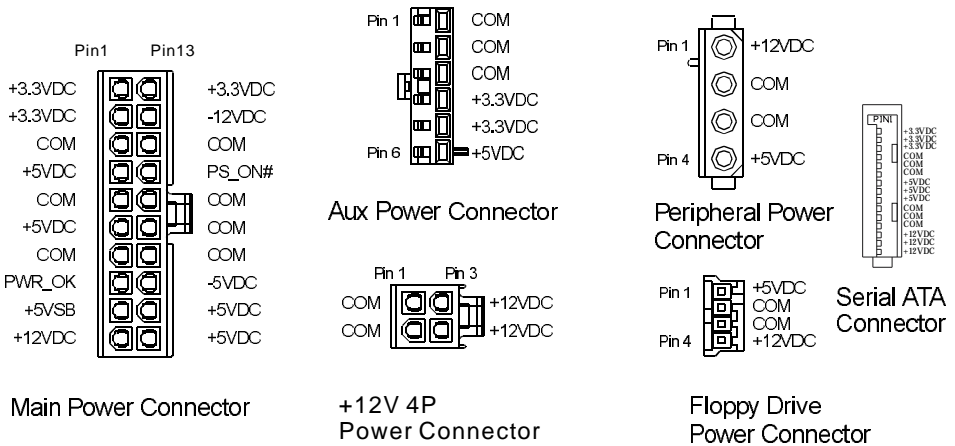

Pin-side view, not to scal

6.2. Calbe adaptors

